

Version: ALPHA PROTOTYPE
 Copyright (c) 2006 Chumby Industries
 Please see the HDK license agreement for terms of use at <http://www.chumby.com/legal/developer>
 Not at all confidential

Title		Sheet of	
Size	Number	Drawings	Revision
B	8/12/2006	01	
Date	Filename	Drawn by:	
	01-ARMV5-LinkerPkg.SCHDOC		

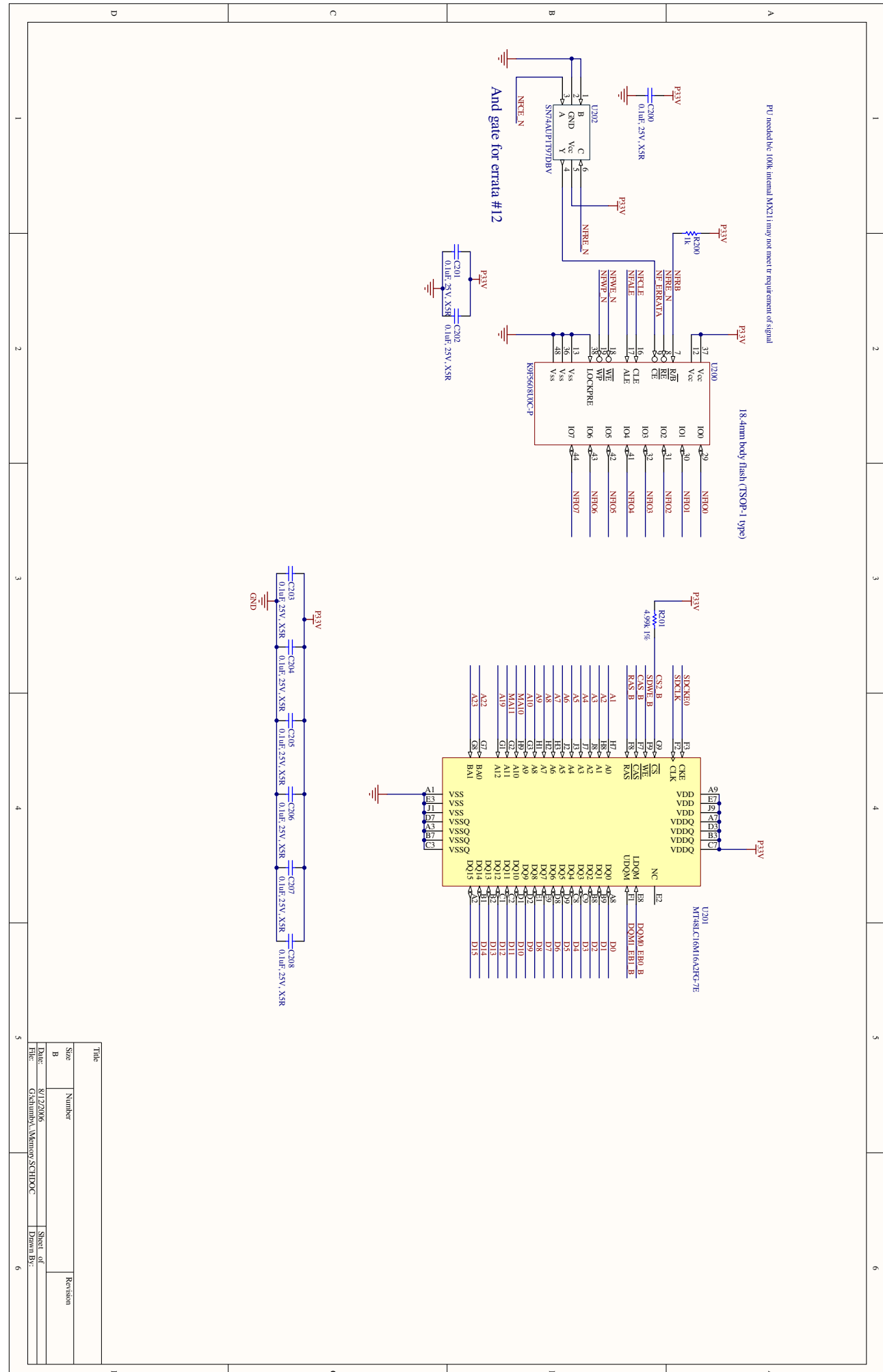

Title	
Size	Number
B	
Date	8/12/2006
File	GasStationMemorySCHEDOC
Sheet of	
Drawn by:	
Revision	
6	

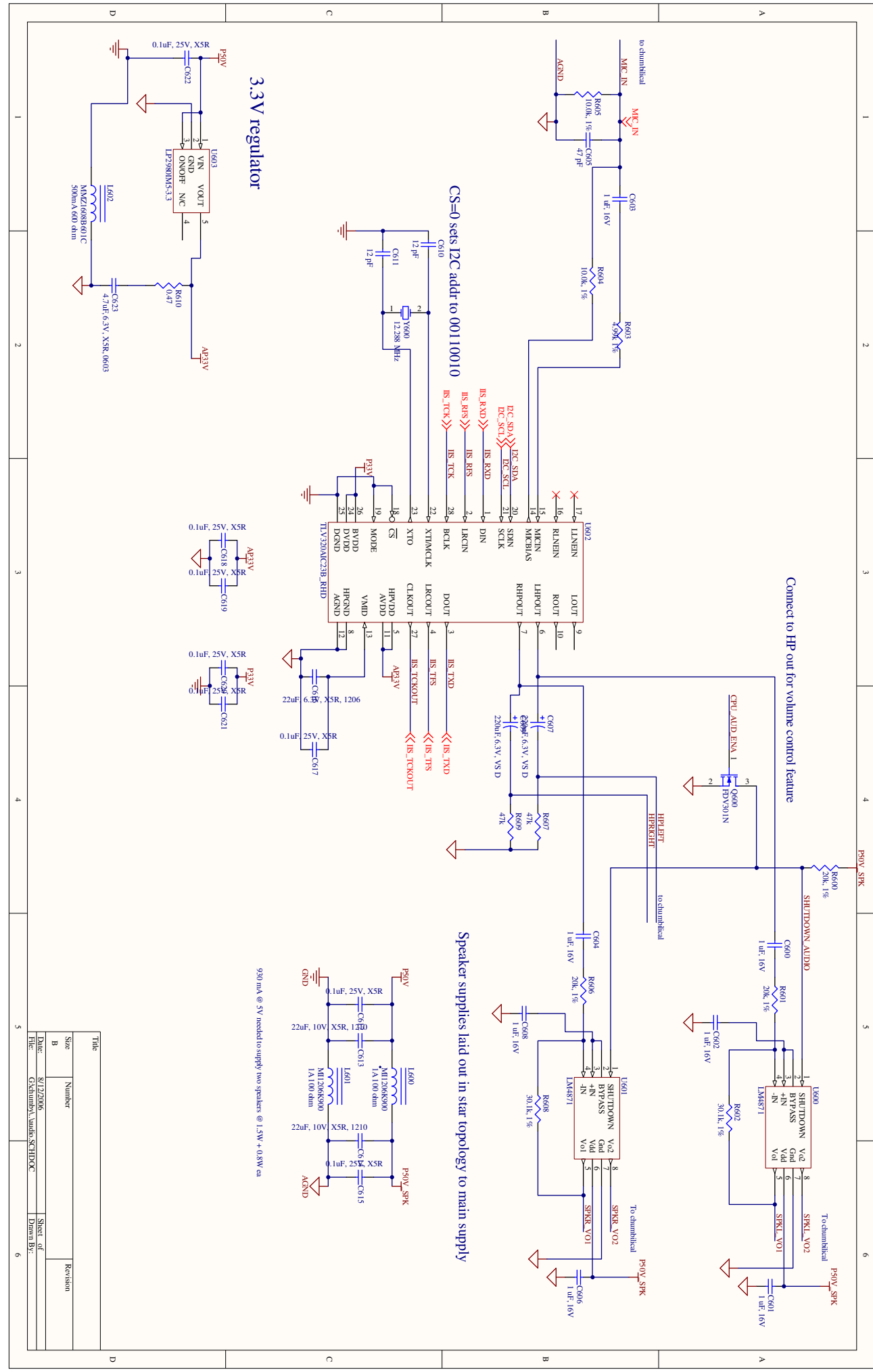

3.3V regulator

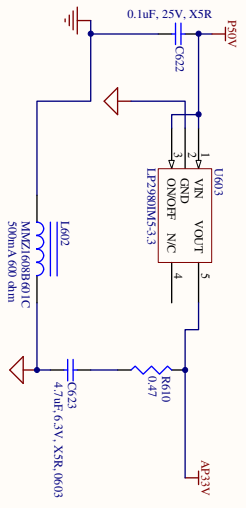

CS-0 sets I2C addr to 00110010

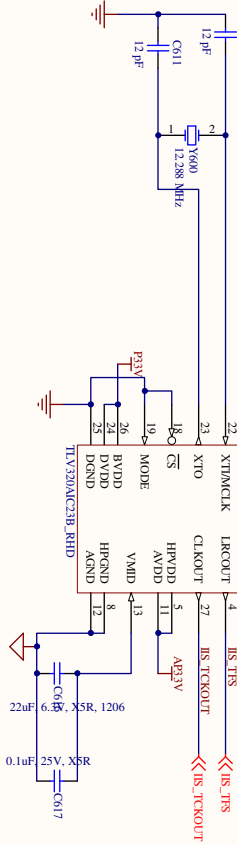

Connect to HP out for volume control feature

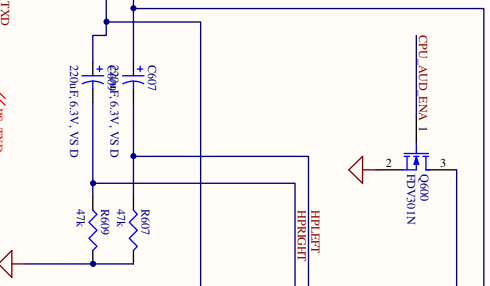

Speaker supplies laid out in star topology to main supply

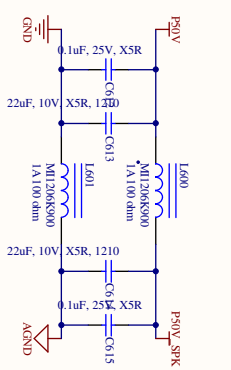

930 ma @ 5V needed to supply two speakers @ 1.5W + 0.8W ea

Title	
Size	Number
B	
Date:	8/12/2006
File:	C:\stammy\sumba\SRTPDOC
Sheet of	1
Revision	

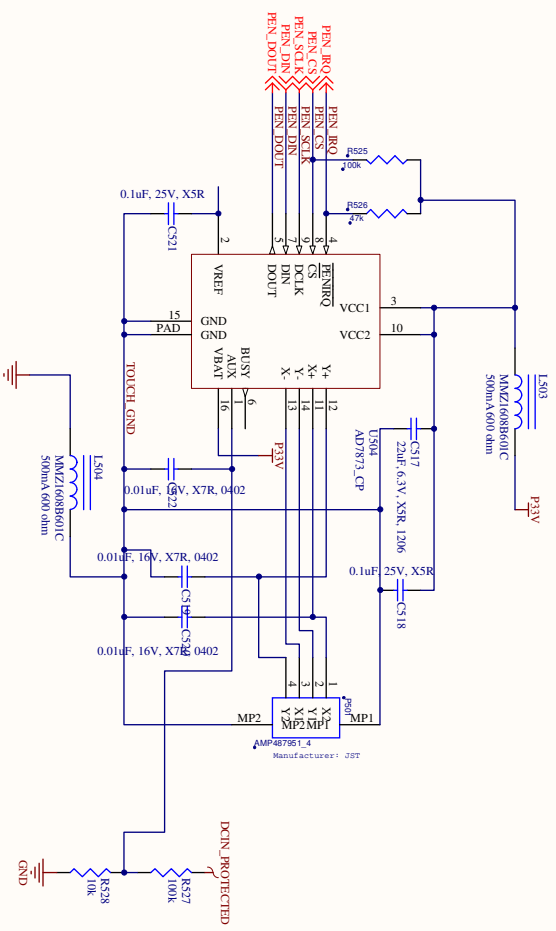

Title		Sheet of	
Size	Number	Revision	
B			
Date	8/12/2006	Drawn by:	
File	GA50005A_LCD_Functional_SCHDOC	6	

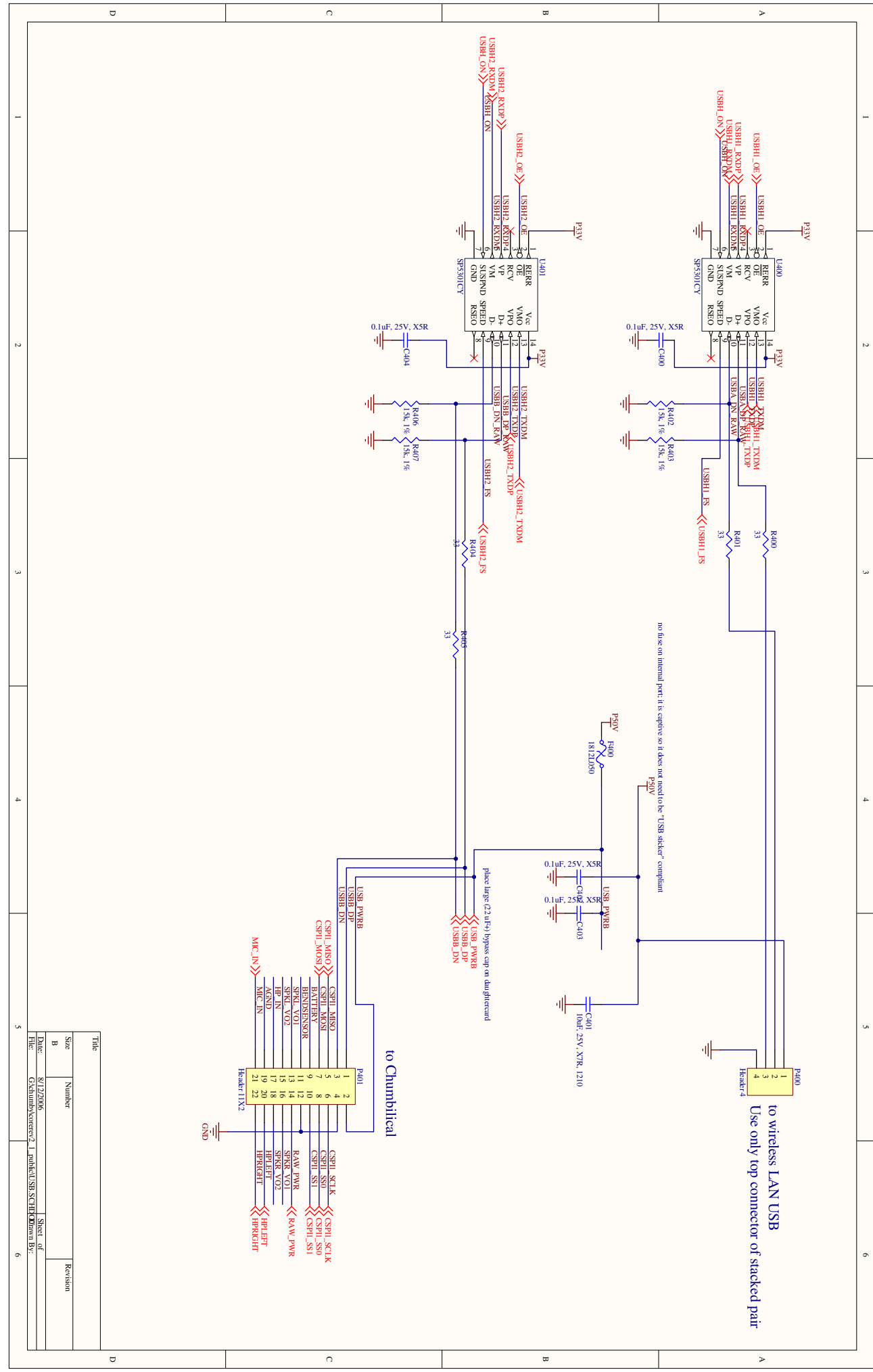

to wireless LAN USB
Use only top connector of stacked pair

to Chunchical

Title		Sheet of	
Size	Number	Revision	
B			
Date	8/12/2006	Date	
File	C:\shimadzu\systems\3_1_public\USB_SCTE\USB_SCTE.DWG	File	